

# TECHNICAL DATA

SINGLE DRUM ROLLERS

BW 211 D-5, BW 211 PD-5

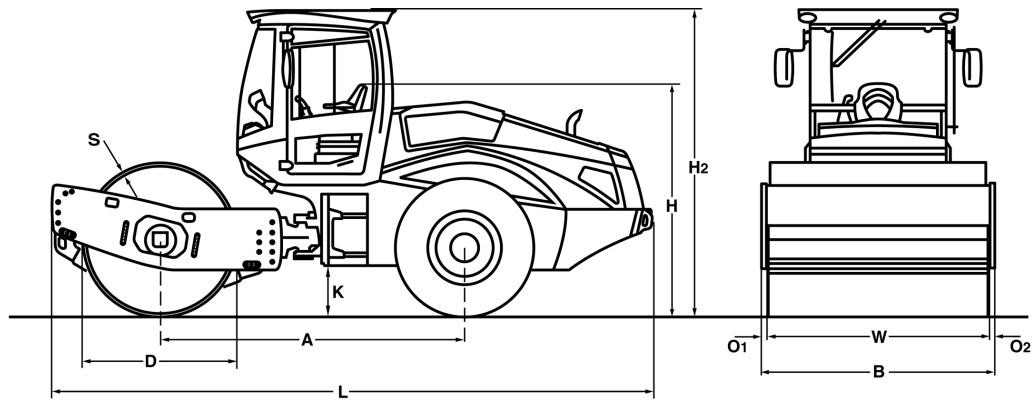



**Dimensions in mm**

	<b>A</b>	<b>B</b>	<b>D</b>	<b>H</b>	<b>H2</b>	<b>K</b>	<b>L</b>	<b>O1</b>	<b>O2</b>	<b>S</b>	<b>W</b>
<b>BW 211 D-5</b>	2975	2270	1500	2260	2990	490	5870	70	70	25	2130
<b>BW 211 PD-5</b>	2975	2270	1480	2260	2990	490	5870	70	70	25	2130

**Shipping dimensions in m3**

**BW 211 D-5**  
**BW 211 PD-5**

**without ROPS**

30,114  
30,114

**with ROPS**

39,841  
39,841

<b>Machine type</b>	<b>Compaction output (m3/h)</b>			
	<b>Rock fill</b>	<b>Gravel, sand</b>	<b>Mixed soil</b>	<b>Silt, clay</b>
BW 211 D-5	400-800	270-540	220-440	110-220
BW 211 PD-5	400-800	270-540	220-440	110-220

<b>Machine type</b>	<b>Compacted layer thickness (m)</b>			
	<b>Rock fill</b>	<b>Gravel, sand</b>	<b>Mixed soil</b>	<b>Silt, clay</b>
BW 211 D-5	0,70	0,50	0,40	0,20
BW 211 PD-5	0,70	0,50	0,40	0,25

**Technical Data****BOMAG  
BW 211 D-5****BOMAG  
BW 211 PD-5****Weights**

Grossweight .....	kg	12.890	12.750
Operating weight CECE w. ROPS-cabin .....	kg	10.600	12.100
Axle load, drum CECE .....	kg	5.670	7.170
Axle load, wheels CECE .....	kg	4.930	4.930
Static linear load CECE .....	kg/cm	26,6	

**Dimensions**

Working width .....	mm	2.130	2.130
Track radius, inner .....	mm	3.680	3.680

**Driving Characteristics**

Speed (1) .....	km/h	0- 5,0	0- 5,0
Speed (2) .....	km/h	0- 6,0	0- 6,0
Speed (3) .....	km/h	0- 8,0	0- 8,0
Speed (4) .....	km/h	0- 11,0	0- 11,0
Max. gradeability without/with vibr. ....	%	51/48	54/51

**Drive**

Engine manufacturer .....		Deutz	Deutz
Type .....		TCD 3.6 L4	TCD 3.6 L4
Emission stage .....		Stage IIIa / TIER3	Stage IIIa / TIER3
Cooling .....		Liquid	Liquid
Number of cylinders .....		4	4
Performance ISO 3046 .....	kW	90,0	90,0
Performance SAE J 1995 .....	hp	121,0	121,0
Speed .....	min-1	2.000	2.000
Fuel .....		diesel	diesel
Electric equipment .....	V	12	12
Drive system .....		hydrost.	hydrost.
Drum driven .....		standard	standard

**Drums and Tyres**

Tyre size .....		23.1-26 12PR	23.1-26 12PR
-----------------	--	--------------	--------------

**Brakes**

Service brake .....		hydrost.	hydrost.
Parking brake .....		hydromec.	hydromec.

**Steering**

Steering system .....		oscil.artic.	oscil.artic.
Steering method .....		hydrost.	hydrost.
Steering / oscillating angle +/- .....	grad	35/12	35/12

**Exciter system**

Drive system .....		hydrost.	hydrost.
Frequency .....	Hz	30/34	30/34
Amplitude .....	mm	1,95/1,00	1,70/0,90
Centrifugal force .....	kN	240/158	285/194
Centrifugal force .....	t	24,5/16,1	29,1/19,8

**Capacities**

Fuel .....	l	250,0	250,0
------------	---	-------	-------

Technical modifications reserved. Machines may be shown with options.

### Standard Equipment

- BOMAG ECOMODE
- No-Spin differential lock
- Rear axle with twin spring accumulator brakes
- Hydrostatic travel and vibration drive
- Hydrostatic articulated steering
- Articulated joint lock
- Seat with arm rest and adj. for position and height
- Sliding window
- Battery disconnect switch
- Single lever control for travel and vibration
- Warning, information and operation displays with LCD
- Loading mode
- Emergency STOP
- Working lights front / rear
- Back-up alarm
- Noise insulation
- 2 Scrapers
- Warning horn

### Optional Equipment

- ROPS/FOPS cabin with seat belts
  - Sliding window
- ROPS/FOPS with safety belt
- Rearview camera
- Air condition
- Radio (Bluetooth)
- Pre start cabin heating
- Comfort package: Adjustable seat and adjustable steering column
- Rotary beacon
- Indicator and hazard lights
- BOMAG ECOSTOP
- TERRAMETER
- BOMAG TELEMATIC POWER
- BCM 05 Documentation system
- Special painting
- Padfoot segment kit (D)
- Environmentally compliant hydraulic oil
- Measuring- and machine data interface for third-party suppliers

